

MECH Curriculum Flowchart AY26-27

Prerequisite →
 Prerequisite C- or above →
 Pre- or Co-requisite - - - →

First Year

Fall
 Winter
 Spring

CHEM 11/L

MATH 11
FWS

CTW 1

MECH 10L

C&I 1

MATH 12
FWS

CTW 2

PHYS 31/L

MECH 12L^{101L}

C&I 2

MECH 15/L¹¹⁴
FS

MATH 13
FWS

PHYS 32/L

ENGR1 & 1L
FWS

Sophomore

Fall
 Winter
 Spring

MECH 11
FW

MATH 14
FWS

PHYS 33/L

CENG 41

MECH 45/L
WS

AMTH 106
FWS

MECH 121/R

CENG 43/L
WS

MECH 103/R
FS

ECEN 50/L
FWS

MECH 140/R
FS

CORE 1

Junior

Fall
 Winter
 Spring

AMTH 118
FW

MECH 122/L
FW

MECH 141/L
FW

MECH 114^{15/L}
WS

CORE 2

ENGL 181
FWS

CORE 3

CORE 4

MECH 123/L

MECH 142/L
WS

MECH 115
FS

CORE 5

Senior

Fall
 Winter
 Spring

TECH 1

MECH 160/L

MECH 101L^{12L}

MECH 194

CORE 6

TECH 2

MECH 195

CORE 7

TECH 3

MECH 196

CORE 8

or

MECH Curriculum Flowchart AY26-27 (MATH 9 Start)

Prerequisite →
 Prerequisite C- or above →
 Pre- or Co-requisite - - ->

First Year

Fall
Winter
Spring

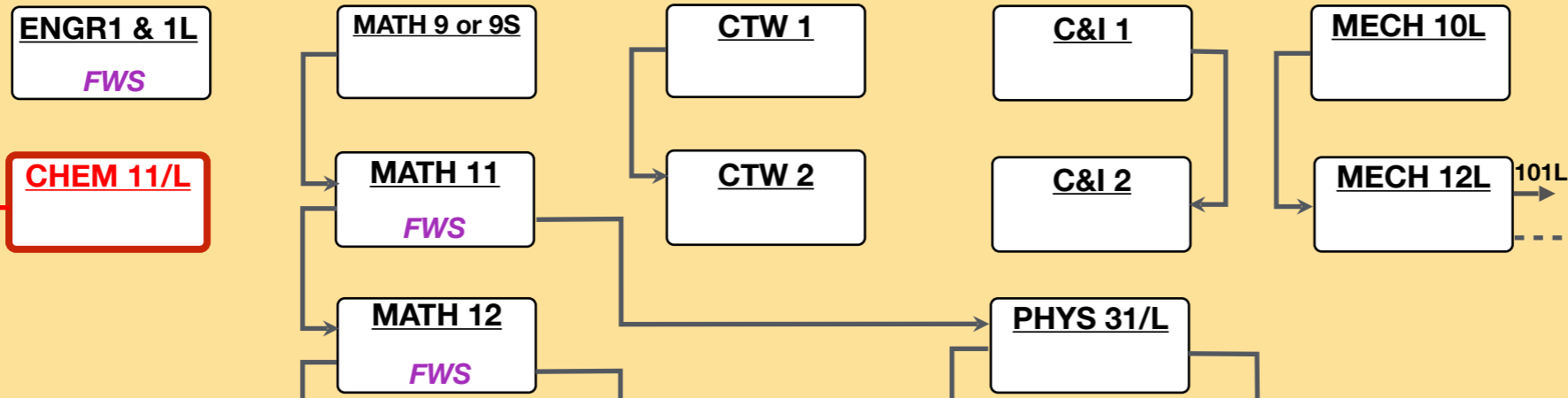

Sophomore

Fall
Winter
Spring

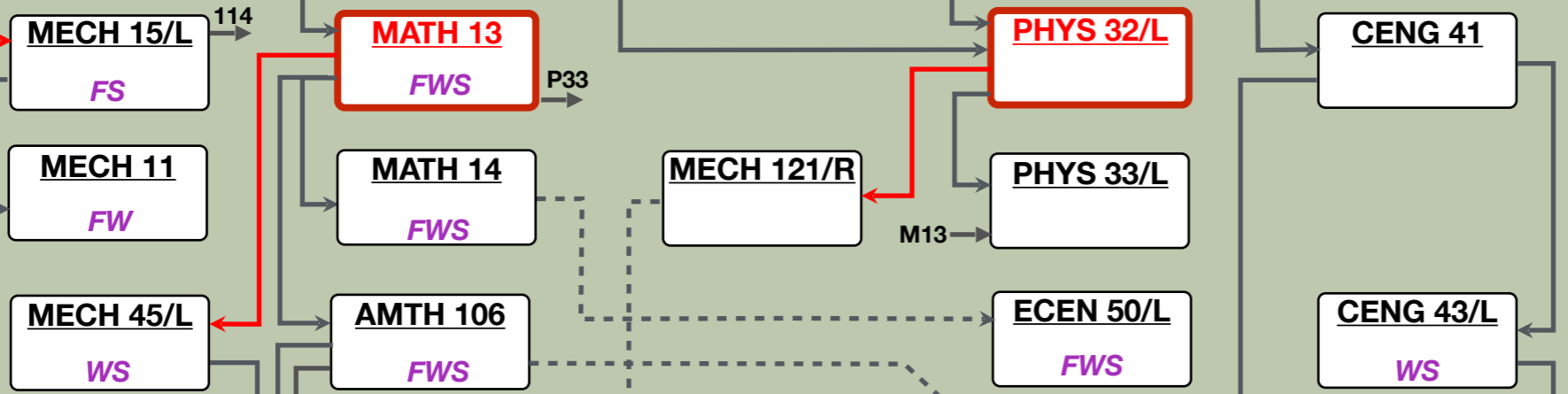

Junior

Fall
Winter
Spring

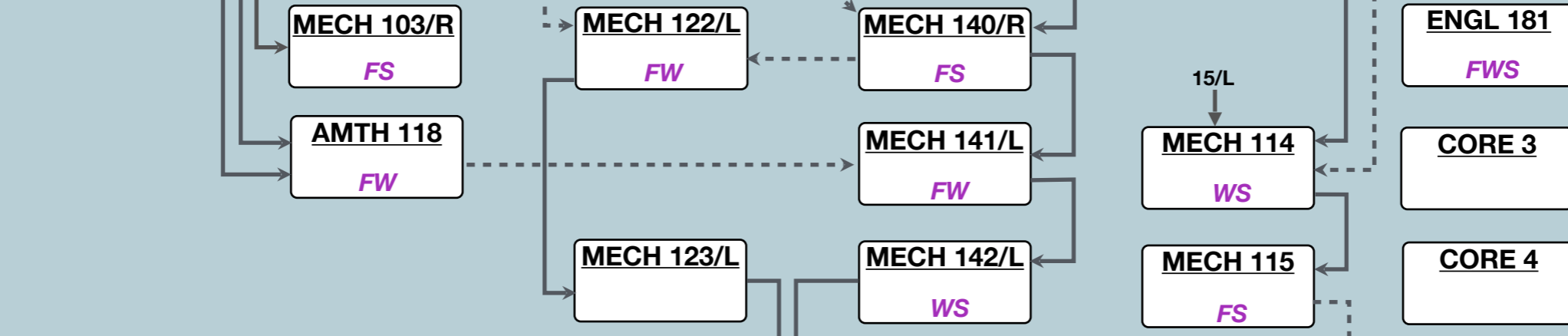

Senior

Fall
Winter
Spring

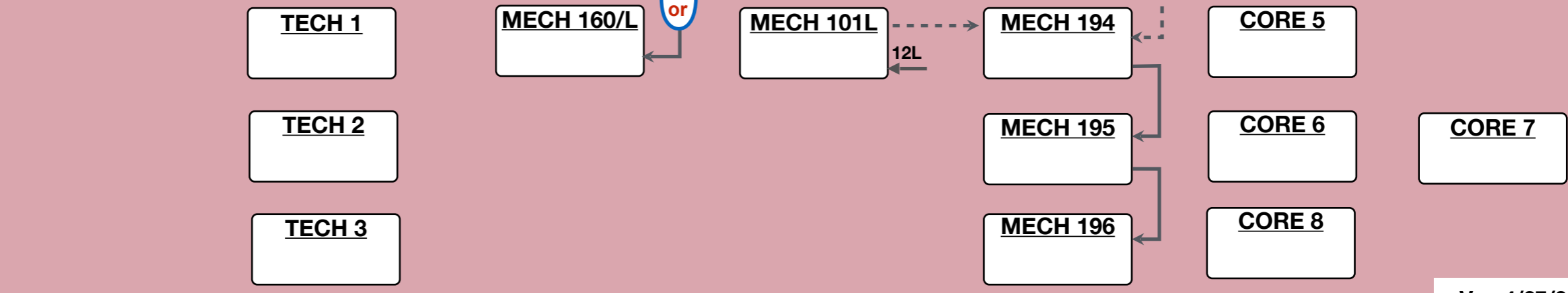



Mechanical Engineering Curriculum Flowchart

Additional Notes

Information in this document is superseded by the official policies in the [Undergraduate Bulletin](#)

ENGR 1/L

FWS

1. Students must meet prerequisites in order to take courses that are connected with arrows. Co-requisite courses can be taken in the same quarter, if they are available.
2. Courses denoted with **F**, **W**, and/or **S** are offered in fall, winter, and/or spring. However, if you wish to take any class in an alternative quarter, you **MUST** check with your advisor or appropriate department to verify that the class will be offered in the quarter. It is safe to assume that most major courses are offered only once a year. We sometimes offer MECH courses (e.g., 121/R) over the summer, but they can be canceled if enrollment is not large enough.
3. You will need to earn the minimum performance of **C- for Courses in red** in order to take subsequent MECH courses. If you do not satisfy this requirement, you will need to retake those courses. The major courses that have this requirement are connected with **red arrows**.
4. ECEN 50/L is recommended to be taken before MECH 160/L.
5. The prerequisites of MECH 160/L are MECH 123/L **“or”** MECH 142/L.
6. Graduation requirements include completing 192 units, satisfaction of the university core and department requirements, and **2.0** GPA, **overall** and in the **major** including math/science.
7. Ethics statement: The Department of Mechanical Engineering values academic integrity as described in the University policy. The learning derived from a course is based on student integrity and faculty support of a just learning environment. The faculty strive to enforce the policy and are open to any questions and discussion from the students. For deeper discussion and useful tips, it is suggested that all students read the information found at <https://www.scu.edu/academic-integrity/>

Core

The Santa Clara Core Curriculum consists of two phases of academic work designed to foster developmental learning and curricular coherence – Foundations and Explorations – and a third phase – Integrations – designed to help students make a connections among courses in the Core and between the Core and the major: For Core 1-8 and Technical Writing the student needs to satisfy the following requirements. For more details: <https://www.scu.edu/provost/core/>

1. Religion, Theology, and Culture 1, 2, 3 (three classes, one at each level).
2. Social Science
3. Diversity
4. Cultures & Ideas 3
5. Experiential Learning and Social Justice
6. Ethics
7. Technical Writing, ENGL 181, is to be taken in the junior year.
8. Civic Engagement, Arts, and other requirements are satisfied through classes already required (e.g., ENGR 1/L & Senior Design); RTC 1 is recommended to be taken in first open core slot.
9. Pathways: clusters of courses with a common theme to promote integrative and intentional learning. Students should make reflective and intentional choices to study a theme from multiple disciplinary or methodological perspectives and to perceive connections. Engineering students need to take 3 pathway courses. For more details: <https://www.scu.edu/provost/core/integrations/pathways/>
10. Students must consult with one of the University advisors in the Drahnann Center before making any changes in their enrollment in the C&I and CTW sequences.

Dos & Don'ts

1. **Do not withdraw any course before talking to your academic advisor. Arrange a meeting with your academic advisor when you earn an F.** Send your **unavailable** time slots so that they can arrange a meeting with you. The purpose of the meeting is to advise you on the modified plans while attempting to keep your graduation within 4 years. Withdrawing does not necessarily lead to more than 4 years, but lack of communication may lead to additional quarters or years.
2. The MECH curriculum is based on a strong foundation of math and science. The content that you learned in your first two years will appear repeatedly in upper-division MECH courses. Please utilize existing resources, such as office hours, tutoring, and the math learning center, in order to enhance your learning outcomes.
3. If a course is closed before your enrollment period starts, please reach out to the Department Manager of the department that offers the course. Include your grade for prerequisites courses and a screenshot of your tentative weekly schedule. Meanwhile, please try to find another course that fits your schedule.
4. Whenever you have concerns or questions, please reach out to your academic advisor or the department chair. We are here to help you!

Study Abroad (in Fall of Junior Year)

- If you are interested in the study abroad program, please talk to your advisor in your first year, or as soon as possible. You may find more general information about the program through the SCU Study Abroad [website](#).
- To study abroad in Fall of your junior year, you must apply in Fall of your sophomore year. The application period begins in mid-November.
- The following flowchart shows an example of how to arrange your sophomore & junior schedule to study abroad and stay on track for a four-year graduation in MECH.
 - The key is to finish **AMTH106** by Winter of your sophomore year. Consider utilizing the Summer after your first year to meet this goal. If you are unable to meet this target, it does not mean you cannot study abroad, but options can be limited.
 - In order to make your study abroad experience possible, you may experience busier quarters in your sophomore and/or junior year. Nevertheless, it is once in a lifetime experience, and definitely worth the challenge.

